

Instruction Manual

ELECTRIC HIGH PALLET TRUCK



Capacity: 1000kg

Note: Owner/Operator must read and understand this instruction manual before using the truck.

Specifications

Model	1056E
Rated capacity	1000kg
Lifting height	800mm
Height of lowerd fork	85mm
Width across fork	1056mm
Fork width	160mm
Fork length	1190mm
Front load roller	Ø75x75mm
Steering wheel	Ø180x55mm
Lifting time with rated load	19s
Lifting time without load	11s
Battery	12V/68Ah
Weight	158kg

Precaution

1. Read the manual carefully before operation. Go through every procedure as required in the manual.
2. Lifting the fork to its full range by 1 to 2 times before use to release the air in the hydraulic system.
3. It is prohibited to lift or pull person.
4. It is prohibited to work on the slope or tilt ground.
5. It is strictly prohibited to put your hand or foot under the fork or in the moving parts.
6. Put the load in the center of the fork. Eccentric loading is strictly prohibited.
7. The safety valve in the pump station will be automatically open when it is overloaded. Under such circumstances don't try to lift the load any more by push the "UP" button otherwise that will reduce the life time of the pump station.
8. Switch off the electricity after use.
9. To replace or fill hydraulic oil, the fork should be lowed to its bottom position. The oil to be used should be clean and filtered.

The condensation point of the oil should be $\leq -20^{\circ}\text{C}$, the motion viscosity 20 – 30 cst (centistrokes).

HOW TO ASSEMBLE AND OPERATE

1. Assembly after opening the package

1. Take down Screw (33) and Pinion (32) accordingly.
2. Insert Handle (35) into the handle seat of the Cylinder unit (1900). Put in Pinion (32). Screw in tightly with Screw (33). Put Adjusting Screw (37) (at the lower end of the Chain) into the slot of the Swing Rod (124).
3. Push down the Handle (35), making the Pump Piston (108) downward meantime, to take away Block (60). Thus Handle (35) would be able to return to its upright position. Keep Pulling Handle (49) in the middle position (2). Operate the he Handle (35) up and down freely without any feeling of the blocking.
4. Put the Pulling Handle (49) at the low position (1), operate Handle (35), the fork should be able to lift to its highest position; at the position (3), the fork should be able to lower to its bottom position steadily.
5. Keep Pulling Handle (49) in low position, pump Handle (35) to lift the fork to its highest position. Take away part (212) and cover (215). Place the Battery (214) into battery tank in the front of Part (25). Connect Connector (241,242) to (+) (-) poles accordingly. Tighten the screws on the Connector. Place part (212) and Cover (215) in. Finally descend fork to its lowest position.
6. Insert Wire and Plug (239) [under Handle (35)] into Socket (239) [under Pump Cover (226)]. Check all electric components such as wire, plug etc. to see if there is any loose, break and short-cut. If everything is normal, switch on the General Switch (236), check the Current Meter (240), the electricity should be over 3 lines. Below 3 lines (in the red light area), the battery should be charged.
7. Check pipes in hydraulic system, see if there is any leakage or seeping.
8. Place Pulling Handle (49) on Low Position (1), press Up-Button (238) intermittently, the fork should be able to ascend accordingly. Observe electrical parts and hydraulic system to see any abnormality. If every thing is normal, press Up-Button to lift the fork to its highest position. The Spacing should effect. Then place Pulling Handle (49) to its highest position (3), the fork should be able to ascend smoothly.
9. Repeat the above said procedures for 2 or 3 times to see if there is any abnormality and to drive air away from hydraulic system. The machine is ready for use.

2. Operation

- 1) When the machine is ready for use, pull the machine on to a flat solid ground. Push forward and backward. The right and left wheel should swivel flexibly.
- 2) Manual ascending: Place Pulling Handle (49) on Low Position (1), operate Handle (35), the fork should ascend smoothly. Place Pulling Handle (49) on Up Position (37), the fork should descend smoothly to lowest position. Release Pulling Handle (49) onto Mid-position (2), the fork should stop on any position, no descending.
- 3) Electric ascending: Turn on Switch (236). Electricity indicator should be above red line, ie. Green light should be on. Place Pulling Handle (49) on Low Position (1). Press down Ascending Switch (238). The fork should ascend smoothly. Release the Ascending Switch (238), the fork should stop on any position no descend. Place Pulling Handle (49) on Up Position (3), the fork should descending smoothly. Release the Pulling Handle (49) to Mid-position, the fork can stop at any position.
- 4) This machine is equipped with safety valve to prevent overload. Neither Manual ascending nor Electrical ascending can ascend under overload.
- 5) After use, turn off Switch (236) to cut off electricity. The electricity meter turns off.
- 6) When ascending speed remarkably slows down while no green light is on in Electricity Meter (240), The Battery (214) should be recharged. Put the Output Plug (217) of Recharge (218) into the Socket (217) on the side of the battery, put the Input Plug on the other end into the electricity socket Switch on the recharge. The recharging begins automatically. (Red light on). When the electricity is full, the green light in recharge turns on. The indicator in electricity meter shows between 8 – 10 lines. The recharging usually lasts 4 – 5 hours.

Problems maintenance and adjustment

1. Trouble shooting

Item	Symptom	Possible Cause	Suggested Action
1	Fork can not ascend to highest position	Not enough oil	Fill oil (follow the way in No.3, Fig 3)
2	Fork does not ascend while operate the handle	Pulling Handle(49) is not in right position Air in hydraulic system	Adjust according the way in No.2, Fig 2) To operate the machine up-down to its full range 1-2 times with no load by manual or electrical operation
3	Fork can not descend	1) Pulling Handle(49) is not in right position 2) Fork or other parts are damaged 3) Blocked by foreign object	1) Adjust by following the way in No.2 and Fig 2 2) Replace damaged parts 3) Take away foreign object
4	Fork does not ascend when press ascending switch	1) Pulling Handle(49) is not in right position 2) Switch is broken 3) Fuse melt down 4) Hydraulic pump does not work 5) Electric-magnetic switch is broken	1) Adjust following the way in No.2 and Fig 2 2) Replace switch 3) Replace fuse. (F ₁ 206, F ₂ 207) 4) Check motor 5) Check electric-magnetic switch
5	Motor does not work	1) Motor is broken 2) Connector and plug-socket are loose 3) Battery is worn out 4) Fuse melt down	1) Check or replace motor 2) Check all connectors 3) Recharge battery 4) Check fuse (F ₁ ,F ₂)
6	Electricity in batter is not enough	1) Recharge time is not enough 2) battery is broken	1) continue recharging to 7 – 8 lines 2) Fill in battery liquid or replace battery
7	Seeping oil in piston and pinion	Seals are broken	Replace seals (158)(105)

2. Adjusting position for Pulling Handle(49)

1) Function of three positions:

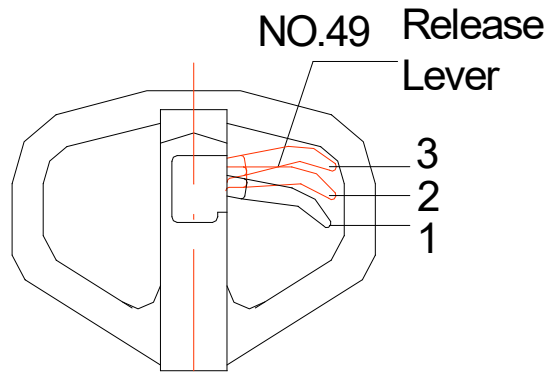

Picture 1

Position 1: ascending the fork

Position 2: neutral

Position 3: descending the fork

2) Adjusting: (Fig 2)

Adjusting Nut (36) if Pulling Handle's position is wrong by following the way below:

Position	Adjusting
On Position 3, fork does not descend	Turn Nut upward anticlockwise (+)
On Position 1, fork does not ascend	Turn Nut downward clockwise (-)
On Position 3, not neutral	Adjusting Nut up and down

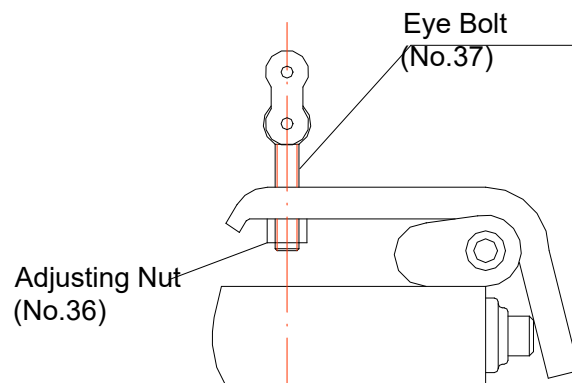

Picture 2

3. Fill oil

Lower down the fork to its lowest position. Turn loose Oiling Screw(132). Fill in clean hydraulic oil(see Attention 8 for technical requirement). Then turn Oiling Screw (132) tight. Press Ascending Switch (238), check if fork can ascend to its highest position. If not, repeat above procedure. Oil filled should just be enough for fork to ascend to highest position. **Don't** fill the hydraulic oil up to filling moth once.

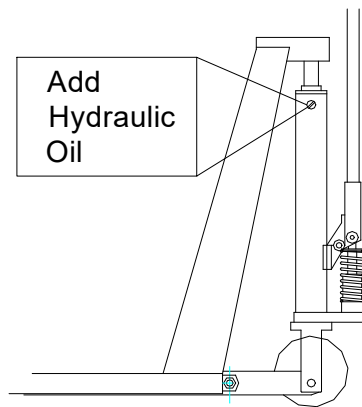

Picture 3

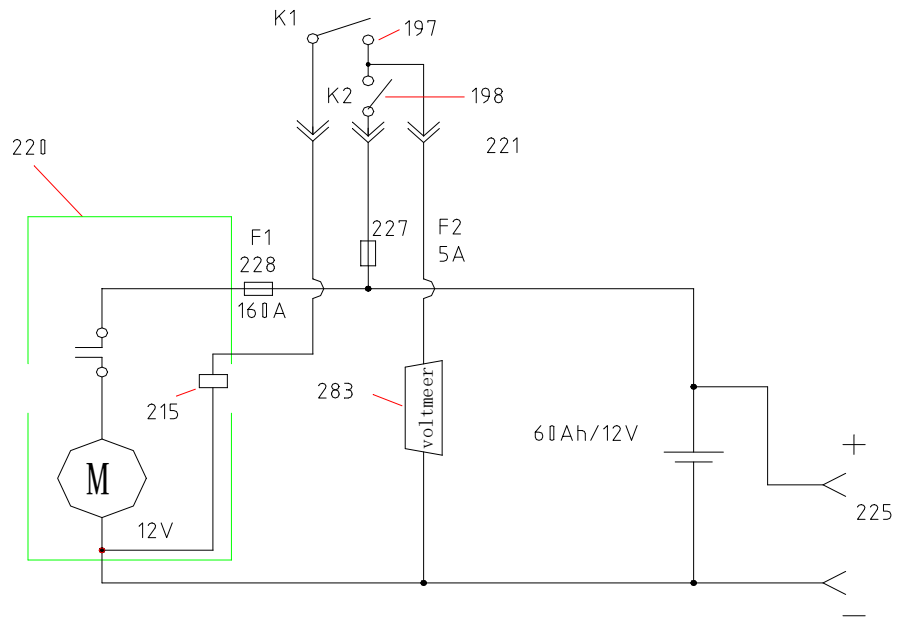

POWER DIAGRAM

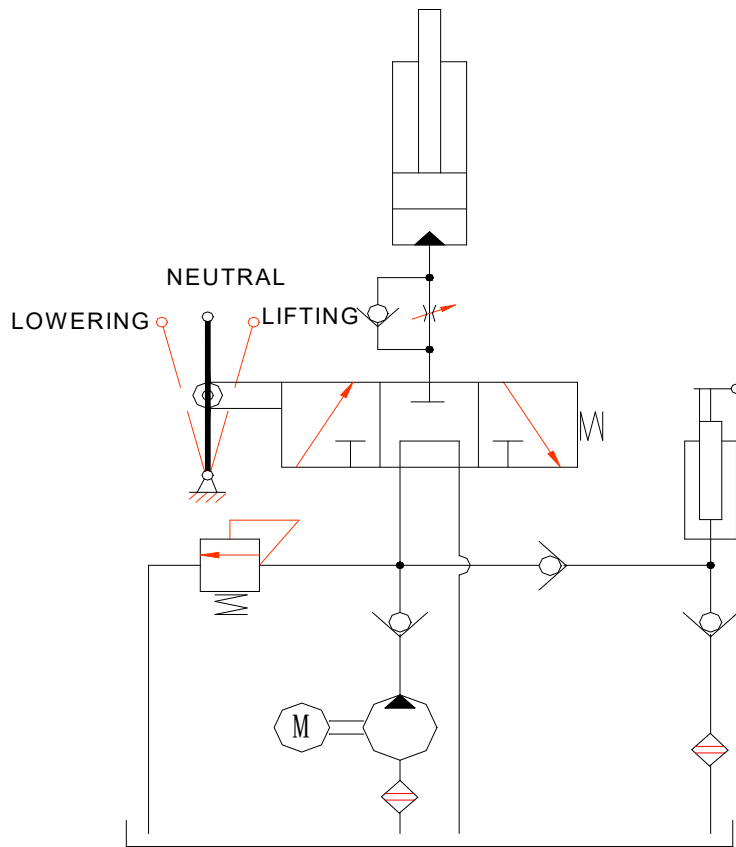
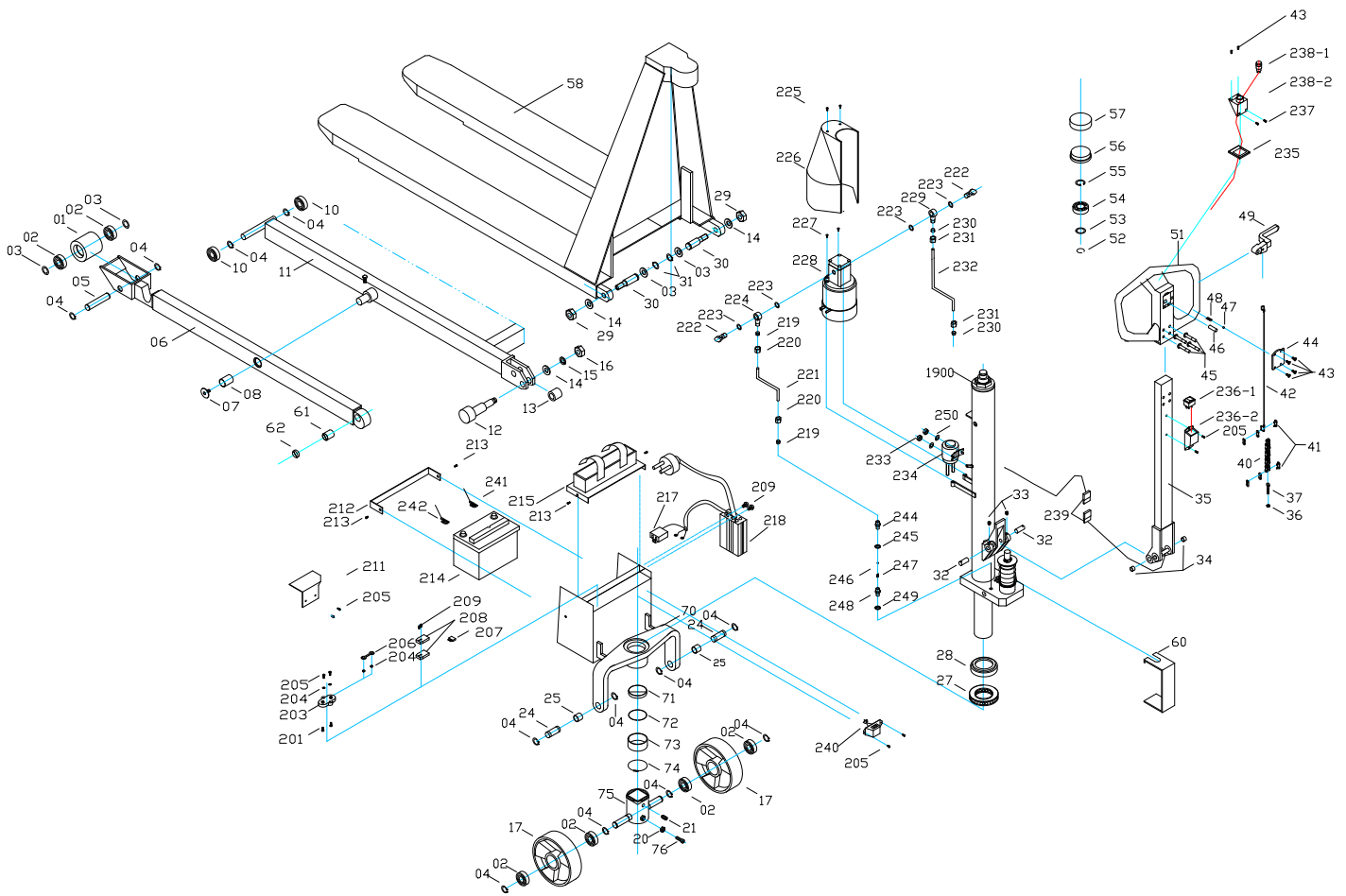

DIAGRAM OF HYDRAULIC SYSTEM



Parts List

No	Description	Qty	No	Description	Qty
01	Front wheels	2	57	Distance disc	1
02	Press	8	58	Forks	1
03	Skies	6	60	Covers	1
04	Laser	16	61	Distance disc	2
05	Stift	2	62	Distance disc	2
06	Ben	2			
07	Screw	2	201	Screw	2
08	Bosnia	2	203	Safety box	1
10	Press	4	204	Engine	4
11	Ben	1	205	Screw	9
12	Centrifugal axis	2	206	Safety(160A)	1
13	Bosnia	4	207	Safety (5A)	1
14	Skies	2	208	Safety box	2
15	Bosnia	2	209	Screw	4
16	Engine	2	211	Covers	1

17	Steering wheels	1	212	Battery welding	1
18	Wheel axle	2	213	Screw	4
19	Screw	2	214	Batteries	1
20	Bosnia	3	215	Covers	1
21	Screw	1	217	Charging plug	1
22	Distance disc	1	218	Charger	1
23	Bosnia	2	219	Distance disc	2
24	Stift	2	220	Bosnia	2
25	Bosnia	1	221	Oils	1
26	Console	1	222	Screw	2
27	Press Rent	1	223	Skies	4
28	Distance disc	2	224	Adjustment screw	1
29	Metric	2	225	Screw	2
30	Stift	2	226	Covers	1
31	Laser	2	227	Screw	2
32	Stift	2	228	Pumps	1
33	Screw	2	229	Adjustment screw	1
34	Bosnia	2	230	Distance disc	2
35	Steering rod	1	231	Metric	2
36	Metric	3	232	Oils	1
37	Bolt	1	234	Relax	1
40	Kade	1	235	Skies	1
41	Road Assemblies	2	236	Contact	1
42	Releasing rod	1	237	Screw	2
43	Screw	6	238	Contact for loft	1
44	Covers	1	239	Stick	1
45	Stift	6	240	Battery indicator	1
46	Stift	1	241	More pole	1
47	Ball	1	242	Minus pole	1
48	Springs	1	244	Adjustment disc	1
49	Release	1	245	Skies	1
51	Grab	1	246	Ball	1
52	Ring welding	1	247	Springs	1
53	Skies	1	248	Adjustment screw	1
54	Press Rent	1	249	Skies	1
55	Ring welding	1			
56	Distance disc	1			

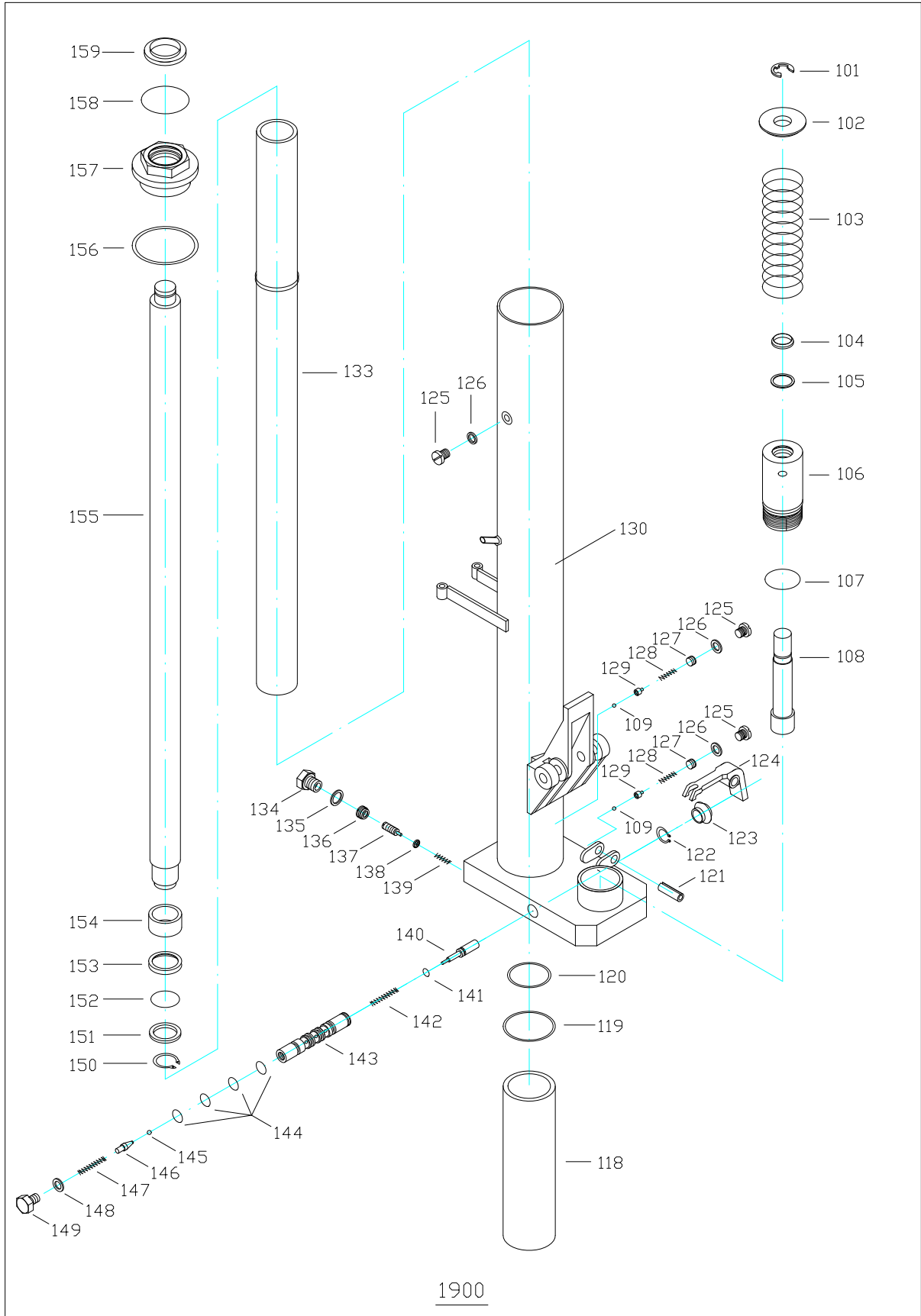

1900

No	Description	Qty	No	Description	Qty
101	Ring welding	1	138	Plate	1
102	Father said	1	139	Spring	1
103	Springs	1	140	Release Indicator	1
104	Contact	1	141	O-Ring	1
105	O-ring	1	142	Spring	1
106	Pumps	1	143	Valve Insert	1
107	O-ring	1	144	O-Ring	4
108	Pump Stamps	1	145	Ball	1
109	Ball	2	146	Release Valve	1
118	Cylinder Error	1	147	Spring	1
119	O-ring	1	148	Seal Ring	1
120	O-ring	1	149	Screw	1
121	Laser	1	150	Snap Ring	1
122	Splitting	1	151	Y-Ring	1
123	Rubber cleaning	1	152	O-Ring	1
124	Pendulbosning	1	153	Retaining O-Ring	1
125	Screw	3	154	Piston	1
126	O-ring	3	155	Piston Rod	1
127	Screw	2	156	Seal Ring	1
128	Springs	2	157	Cylinder Nut	1
129	Stalball	2	158	O-Ring	1
130	Pumphouse	1	159	Scraper Ring	1
133	Cylinder	1			
134	Screw	1			
135	Laser	1			
136	Screw	1			
137	Screw	1			

STILL DANMARK A/S, Essen 1, DK-6000 Kolding

Sales/Admin: 76 31 98 00, Service: 80 81 53 00, Fax: 76 31 98 20, www.still.dk